

- Electrical:
1. Rating: 50mA 12V DC
 2. Contact Resistance: 100mΩ Max.
 3. Insulation Resistance: 100MΩ Min, 100V DC
 4. Dielectric Voltage Proof: 250V AC For 1min
 5. Electrically Life: 10000 Cycles Min.
 6. Operating Force: 250±50gf
 7. Environment Temperature: -30°C~+80°C

- Materials:
- A. Cards: Phosphor 0.12, Plated Nickel Silver
 - B. Pedestal: LCP, White
 - C. Shrapnel: Stainless Steel
 - D. Push Button: PA46, White
 - E. Cover: Stainless steel 0.2

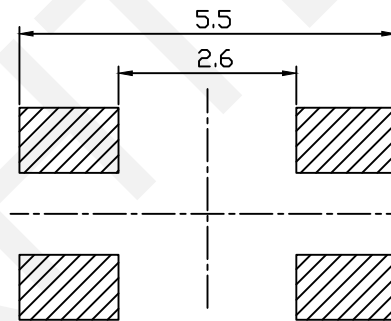
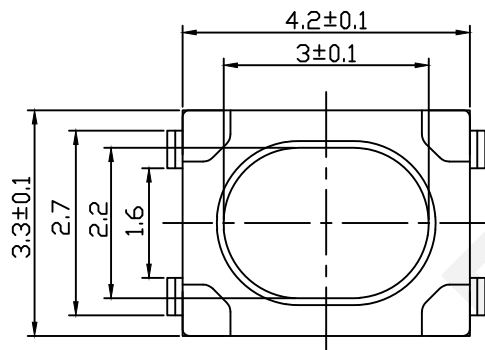

P.C.B Layout

ORDER INFORMATION

RHTGYS3402-2.5-250-B

3x4mm Tact Switch

Height: 2.5mm

Operating Force: 250(±50gf)

Packing: B-Bulk

RHTECP NINGBO RHT ELECTRONIC CO.,LTD

UNITS:mm	SHEET SIZE: A4		SCALE:---	DRWN BY PAN
0~3	3~18	18~50	50~120	CHK'D BY FENG
±0.12	±0.15	±0.3	±0.5	APPR BY ZHAN

3x4mm Tact Switch(U Type)

THIRD ANGLE PROJECTION

RHTGYS3402